

## Anacapa 22" Vanity with Vitreous China Vanity Top and Medicine Cabinet



### AVAILABLE COLOR/FINISH

Matte White (PN: 91221282)

### SET INCLUDES

Main Cabinet, Vitreous China Vanity Top w/Integrated Basin, Medicine Cabinet, Mounting Hardware

### WEIGHT (NET)

Medicine Cabinet: 21 lb

Main Cabinet with Vanity Top: 56 lb

### FEATURES

#### Vanity

- Contemporary Floating/Wall Hung Style
- French Cleat Mounting
- Matching Vitreous China Vanity Top Featuring a Centered Rectangular Integrated Basin
- Comes Preassembled
- Pre-drilled hole in countertop for Single-Hole Faucets
- Pre-drilled Hole for Plumbing
- Constructed with Heavy-Duty PVC Board
- Single Door Cabinet and easy-access Pocket Shelves
- Soft-Closing, Stainless Steel Hinges
- Faucet, drain assembly, and P-trap are **NOT INCLUDED**

#### Medicine Cabinet

- Matching Surface-Mount Medicine Cabinet
- Copper-Free Mirror
- Adjustable Shelves and easy-access Side Shelves
- Constructed with Heavy-Duty PVC Board
- Soft-Closing, Stainless Steel Hinges

### CERTIFICATES & COMPLIANCES

- TSCA Title VI & CARB Phase 2 certified material
- Tested for chemical safety base on CA Pro. 65

### WARRANTY

Limited 1-year, please see full warranty for details

## DIMENSIONS

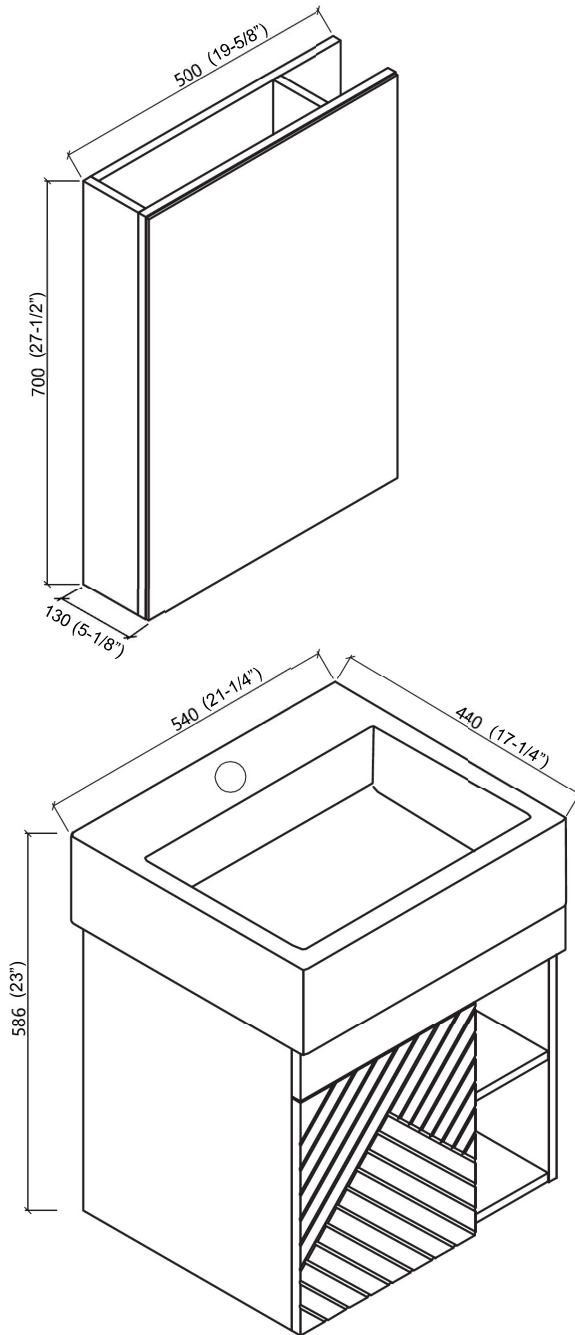

**innoci usa, Inc.**  
Santa Fe Springs, CA 90670

[www.innoci-usa.com](http://www.innoci-usa.com)  
(866) 479-8076

[customerservice@innoci-usa.com](mailto:customerservice@innoci-usa.com)

**innociusa**  
LIFESTYLE

Rev. 2.5